

Asycube 530

Flexible Vibrating Feeder for Parts from 30 to 150 mm

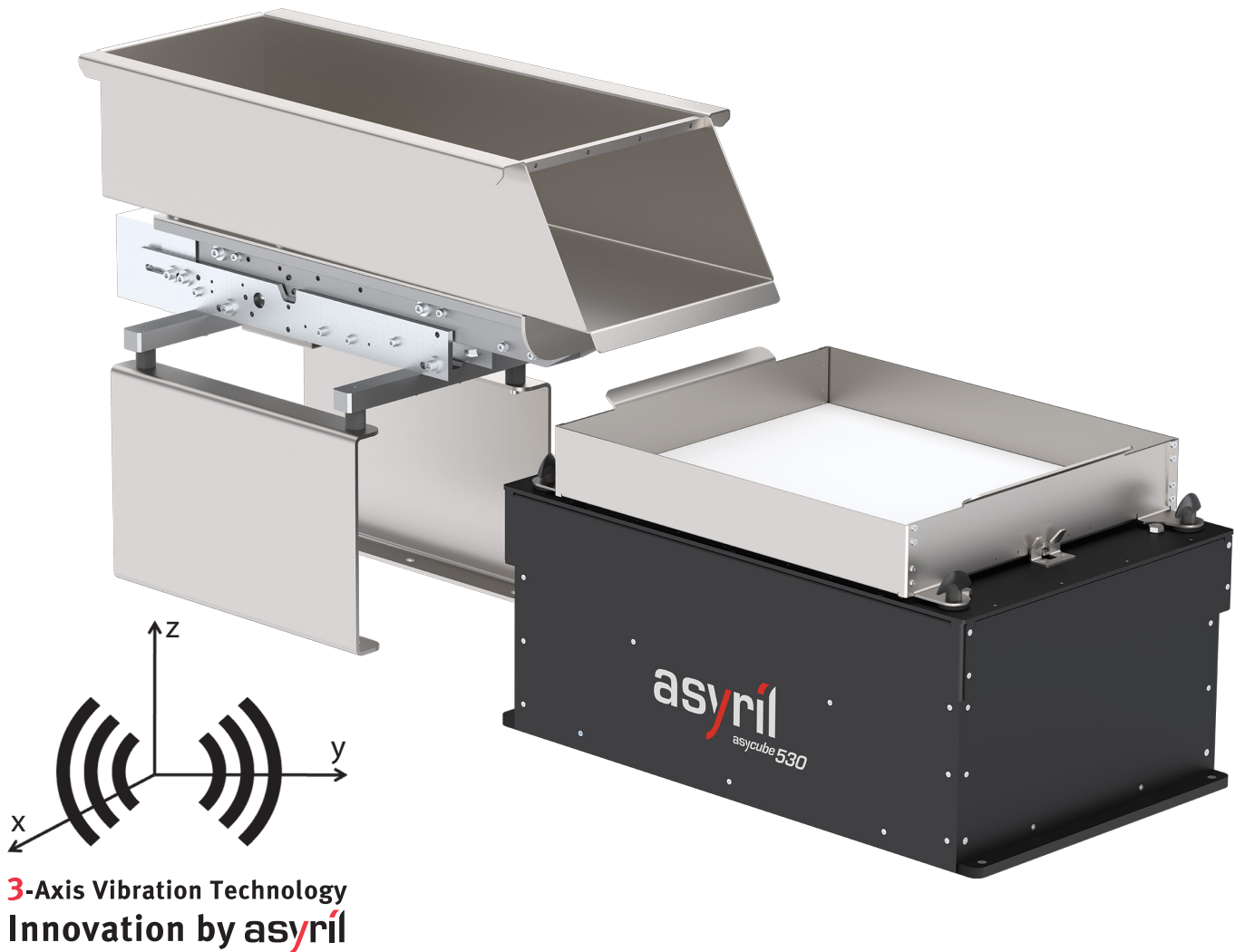

3-Axis Vibration Technology
Innovation by **asyril**

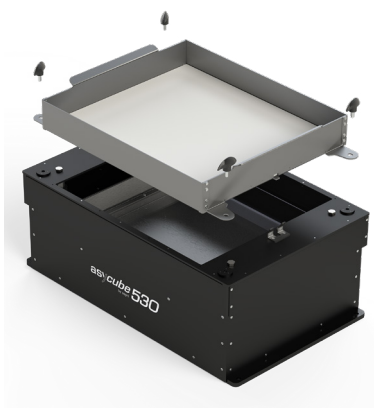

Feeder Advantages

- ▶ **Compatible with all part geometries:** 99% of parts can be fed on our feeders - including complex geometries and delicate materials
- ▶ **Gentle part handling due to Asyri's innovative 3-axis vibration technology:** parts can be moved in all directions, including the optimal choice of flipping amplitude for each part. Minimal abrasion as parts do not need to be recirculated. Platform purge possible
- ▶ **Advanced reliability and durability** due to State-of-the-Art Voice Coil Technology; no compressed air
- ▶ **Precise part detection** thanks to integrated, adjustable backlight / optional EYE+ Smart Control System
- ▶ **Systematic part orientation** can be achieved with intelligently structured platforms (grooves, holes, nests, various materials)
- ▶ **Minimum production changeover times** enable flexible, future-proof production systems
- ▶ **Easy configuration** with Asyri's Feeder Control Center Software
- ▶ **Various hopper sizes**

Asycube 530

Flexible Vibrating Feeder for Parts from 30 to 150 mm

How it works

1. Homogeneous parts separation and orientation using Asyri's innovative 3-Axis Vibration Technology
2. Detection of correctly oriented parts by control system (e.g. EYE+)
3. Part pick from platform and assembly by robot

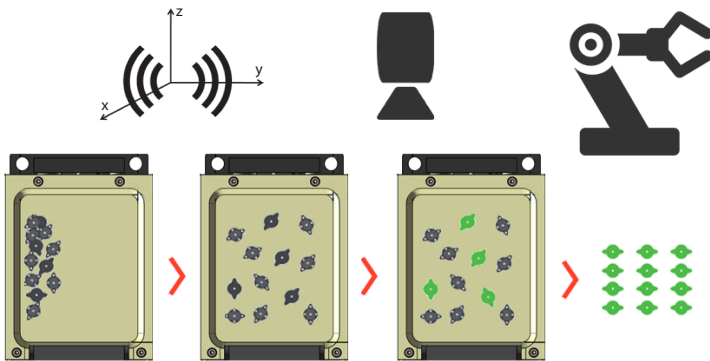

- Parts are spread homogeneously on the feeder surface and can even be systematically oriented in many cases by using intelligent vibration patterns in combination with a structured plate. Entire part families can thus be handled with a single feeder, making the system highly future-proof.

Asyri's innovative 3-Axis Vibration Technology

- Systematic part orientation can be achieved with intelligently structured platforms (grooves, holes, nests).

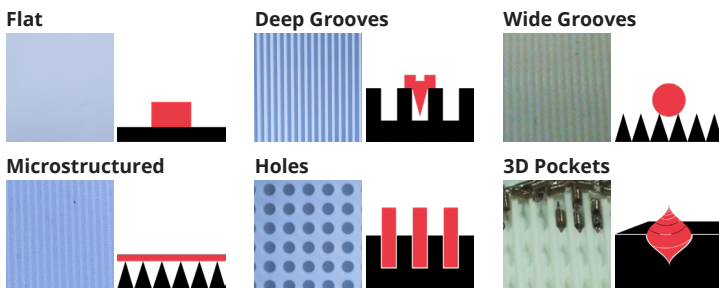

- Asyri's unique and patented 3-axis vibration technology allows moving parts freely on a platform in different directions.
- Using Asyri's intuitive HMI interface, the platform vibration parameters can be tuned specifically for an optimal part distribution and fastest resulting cycle time. A functioning part feeding recipe is typically created in less than 5 minutes

About Asyri

- Asyri develops, produces and markets high performance flexible feeding systems for parts and components from <0.1 up to 150 mm in size. Our innovative 3-axis vibration technology can handle bulk parts of any geometry and allows for extremely gentle part feeding.
- Asyri's key competences and extensive know-how encompass all three sub-domains of modern part feeding systems: vibration technology, industrial vision and precision robotics. This unique focus combined with our many years of experience enable us to deliver superior, innovative robotic feeding systems for today's and tomorrow automation challenges.

Specifications

GENERAL INFORMATION

Power supply	24 V / 20 A
Backlight synchronization input	
Communication Optional via Gateway	Ethernet (TCP/IP), Modbus TCP EtherNet/IP, EtherCAT, PROFINET, CC-Link
Communication Libraries / Software plugins	ABB - FANUC - DENSO - MITSUBISHI ELECTRIC - MICROSOFT.NET - STÄUBLI - UNIVERSAL ROBOTS - YAMAHA - YASKAWA

OPTIONS

Smart Control System	EYE+
Integrated LED backlight	red / green / blue / white / infrared
Vibration plate	flat / holes / grooves / nests / various materials
Connection cables	power / communication / backlight
Hopper size	15 liters
Custom platform material	on demand (e.g. medical)

DIMENSIONS

Description	Reference	Dimensions	
		[mm]	[~inches]
Typical part size		30 - 150	~ 1.6 - 6
Vibration platform	A	370	~ 14.6
	B	427	~ 16.8
Footprint	C	374	~ 14.7
	D	600	~ 23.7
	D'	115	~ 4.5
	E	328	~ 12.9
Maximum height	F	259	~ 10.2
Pick height			

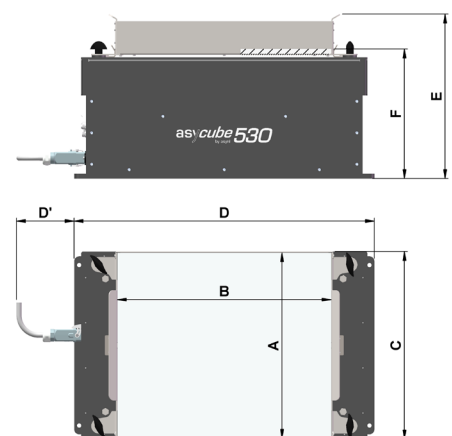

Contact



scan to see the videos
www.asyril.com
 sales@asyril.com
 Tel +41(0) 26 653 71 90
[youtube.com/AsyriSA](https://www.youtube.com/AsyriSA)

Asyri SA
 Z.I. du Vivier 22
 CH-1690 Villaz-St-Pierre
 SWITZERLAND